

Ballina Pyrolysis Demonstration Project





Project Objectives:

The key objective of the project is to demonstrate the technical and economic feasibility of commercial scale processing of waste organics to energy and biochar via an innovative, Australian developed, pyrolysis technology.

Direct outcomes to be delivered include:

- ▶ Climate Change mitigation and adaptation; reducing landfill GHG emissions, sequestering carbon, offsetting fossil fuel use, contributing to the renewable energy target, assisting agriculture to adapt.
- ▶ Creating regional employment.
- ▶ Improved resource recovery from waste organics.
- ▶ Reducing waste to landfill.
- ▶ Generating local renewable electricity in an area with stretched grid capacity.
- ▶ Contributing to local government emissions reductions targets.
- ▶ Nutrient cycling from urban centres back to agriculture.
- ▶ Decreasing agricultural inputs such as synthetic fertilisers.



In-direct outcomes which allow the project to be confidently replicated for the benefit of local governments, industry and farmers, include:

- ▶ Demonstration of pyrolysis technology at a commercial scale.
- ▶ Demonstration of the project business case; including revenues from biochar sales, renewable energy from waste, and carbon offsets.
- ▶ Commercial biochar supply will enable large scale research and development field trials to be established.
- ▶ The greenhouse gas mitigation potential of biochar technology has only been demonstrated on a pilot scale. Large scale biochar production will enable scientific verification of these benefits.

NSW State Plan 2010 Priorities and Targets, to be directly addressed by this project:

- | | |
|--|---|
| <ul style="list-style-type: none"> ✓ Tackle Climate Change ✓ Develop a clean energy future ✓ Improve air quality ✓ Reduce Waste ✓ Maintain and invest in infrastructure | <ul style="list-style-type: none"> ✓ Increase business investment and support jobs ✓ Drive innovation and grow productivity ✓ Ensure a reliable electricity supply |
|--|---|



Business Case Overview:

Estimated Project Capital Cost: \$8.5 million

Project Development Cost: \$1 million

Revenue Streams:

- ▶ Waste service charge (avoidance of State Waste Levy and future CPRS liability on landfill).
- ▶ Electricity sales.
- ▶ Renewable Energy Certificates (RECs).
- ▶ Biochar sales.
- ▶ Carbon offsets (via the voluntary National Offset Standard).

Operating Costs:

- ▶ Staff.
- ▶ Feedstock pre-treatment.
- ▶ Plant maintenance and operation.
- ▶ Ancillary services (electricity, gas).
- ▶ Management, administration and regulatory requirements.

BSC and potential commercial partners (including financial institutions) have reviewed the business case and consider the technology to provide competitive economic outcomes compared with alternatives, especially when considering the additional environmental and social benefits.

Policy uncertainty surrounding carbon offset and REC prices presents a challenge to project financial modelling. The risks associated with implementing a first-of-kind plant at a commercial scale could lead to a delay in project implementation. This risk threshold could be decreased to an acceptable level however if grant funding could be attributed to cover a portion of the capital costs of the project, and/or to provide off takes for project products such as RECs, biochar and carbon offsets.

Project Development Background:

A collaboration was established between the NSW Department of Industry and Investment (NSW DII, formerly NSW DPI), the NSW Department of State and Regional Development (DSRD), and Ballina Shire Council (BSC) to investigate the feasibility of establishing a pyrolysis demonstration facility in North East NSW. The drivers for the work included; regional development, organics waste management, enhanced agriculture productivity, biochar production, renewable energy production, and greenhouse gas mitigation objectives.

Pacific Pyrolysis (PacPyro) Pty Limited (formerly BEST Energies Australia) responded to the consultation brief and was contracted as the collaborative technical partner for the project. PacPyro had previously collaborated with NSW DPI on an extensive biochar research program which attracted a major funding contribution from the NSW Department of Environment and Climate Change (DECC). The findings of this work showed the potential for agronomic benefits and greenhouse gas mitigation from biochar addition to soil. The foundation provided by this early work enabled further funding from several other state and federal government departments for additional biochar research and development that supports commercialisation of the technology.

Project Annual Capacity:

Renewable Energy 6,000 MWh

Biochar 7,000 tonnes

Waste Diverted 29,000 tonnes

Emissions avoided 48,000 t CO₂-e

A project feasibility study has found a business case exists for the application of a pyrolysis plant project at the Ballina landfill site.

BSC and PacPyro have continued to collaborate on development of the pyrolysis project and are currently seeking support so that the project can be implemented in a timely fashion to achieve the greatest possible benefit for the Northern Rivers, NSW and Australia.

Project Technical Outline:

The project is designed to achieve optimised economic and environmental outcomes through the conversion of organic waste, which is currently managed on the BSC landfill site, to electricity and biochar. The pyrolysis technology utilised is a thermal conversion process which has been demonstrated on a 1/10th pilot scale (see www.pacpyro.com for more information). Several levels of technical feasibility assessments have been conducted on the project including site and feedstock specific investigations.

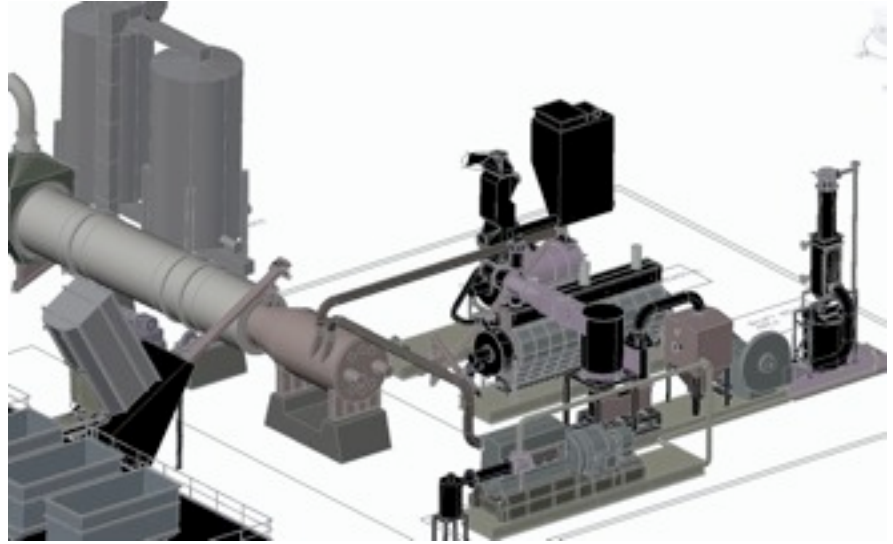

"Adding biochar to soil not only provides an economical way to sequester carbon, but also has soil health benefits which will help farmers adapt to climate variability and increase productivity."

**NSW Minister for State and Regional Development,
Ian MacDonald**



Biochar Research:

The NSW DII Wollongbar agricultural institute has been conducting field trials on biochar in the Northern NSW region since 2006. The results of these trials have been very encouraging and local land managers are keen to apply the new understanding in their commercial operations. Please refer to the peer reviewed scientific publications on the local trials for more information.

Through various State and Federal research grants, biochar research in Australia is beginning to gain momentum. For more information see the projects page of the ANZ biochar researcher's network website. This research has been enabled by the ability of research institutions to gain access to the PacPyro pyrolysis pilot plant, which was built with the support of the NSW DECC, for the production of biochar. However, the small scale of this pilot facility greatly limits the size and quantity of in-field trials possible due to the high operating costs. Commercial scale biochar production will allow the expansion of scientific trials for verification and product development.



For further information please contact
Adriana Downie ,

Pacific Pyrolysis. 56 Gindurra Road,
Somersby, NSW 2250. +61 2 4340 4911

www.pacificpyrolysis.com



For further information please contact
John Truman ,

Ballina Shire Council. PO Box 450,
Ballina, NSW 2478. +61 2 6686 4444

www.ballina.nsw.gov.au

We are very grateful for the support of BSC, NSW DPI, DSRD, PacPyro, and DECC during the development of this project.